

2 mm Square Low-Profile SMT Trimmer Potentiometers (Cermet, Open Frame Type)

Discontinued

Type: **EVM2G**
EVM2N
EVM2W



2G, 2N



2W

Features

- Low-profile
0.85 mm (0.95 mm max.) EVM2G
0.81 mm (0.95 mm max.) EVM2N
1.05 mm (1.2 mm max.) EVM2W
- Automatic adjustment type (EVM2W)
- High reliability realized by cermet element
- Excellent mountability
- Conforms to JIS C5260-1:1999
- RoHS compliant

Recommended Applications

- Audio/visual, office, and communication equipment
- General electronic equipment

Explanation of Part Numbers

1	2	3	4	5	6	7	8	9	10	11	12
E	V	M	2	G	S	X	8	0	B	1	2
Product Code			Type/Structure (2G, 2N, 2W)		Packaging			Taper & Resistance Example : B12=100 Ω			

Specifications

Total Resistance Value Resistance Tolerance	100 Ω to 1 MΩ EVM2G : ±20 %, EVM2N, 2W : ±25 %
Power Rating Limiting Element Voltage	0.15 W 50 V
Rotation Torque	EVM2G, 2N : 0.5 to 10 mN·m EVM2W : 1 to 15 mN·m
Temperature Coefficient of Resistance	±250 × 10 ⁻⁶ /°C

Minimum Quantity/Packing Unit

Part Number	Taping		
	Quantity per reel	Packaging quantity	Dia. of reel (mm)
EVM2G EVM2N EVM2W	3,000	15,000	φ178

The standard packaging methods for a reel is φ178.

Please contact us, if you would like different packaging methods. (Bulk, Reel of φ330, Reel of φ380)

Dimensions in mm (not to scale)

● 3-terminal/Low-profile EVM2G

No. 1

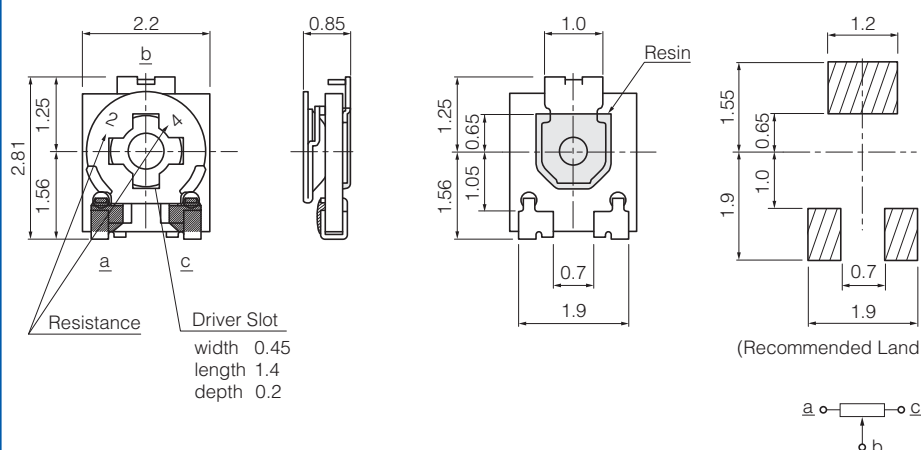
Resistance Driver Slot
width 0.45
length 1.4
depth 0.2

Mass (Weight) : 14 mg/pc.

(Recommended Land Pattern)

(Circuit diagram)

● 3-terminal/Low-profile EVM2N

No. 2

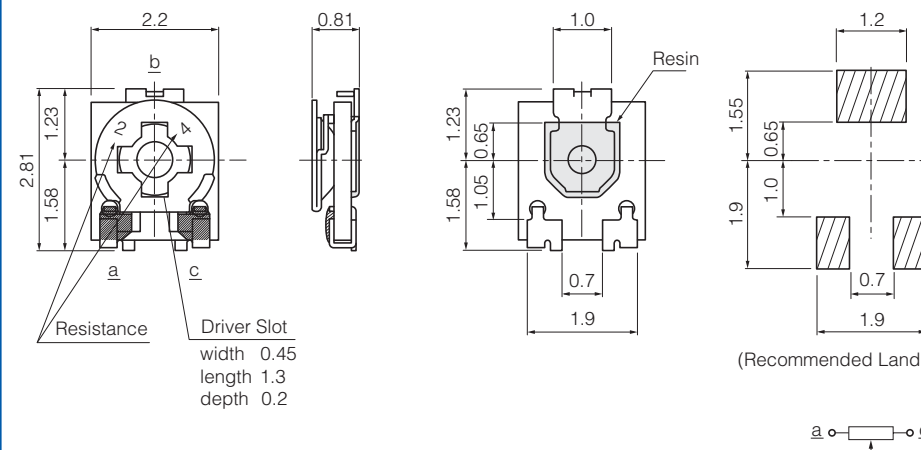
Resistance Driver Slot
width 0.45
length 1.3
depth 0.2

Mass (Weight) : 13 mg/pc.

(Recommended Land Pattern)

(Circuit diagram)

● 3-terminal, for Automatic Trimming Adjustment/Low-profile EVM2W

No. 3

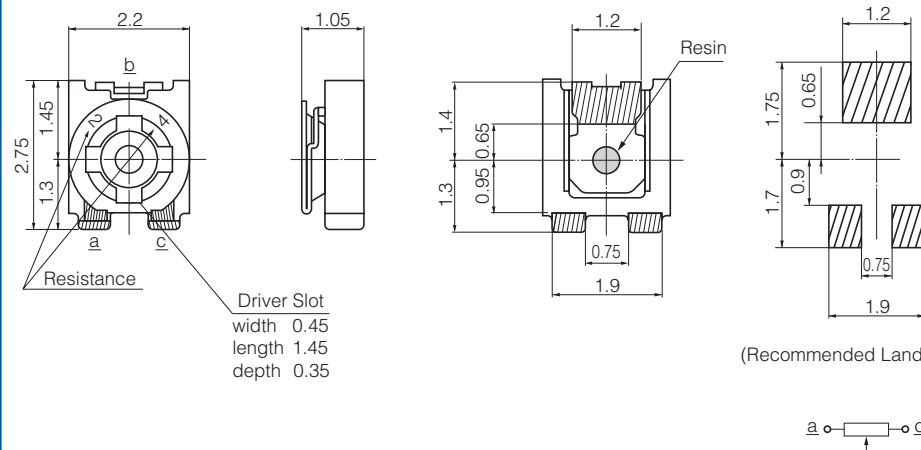
Resistance Driver Slot
width 0.45
length 1.45
depth 0.35

Mass (Weight) : 17 mg/pc.

(Recommended Land Pattern)

(Circuit diagram)

Mouser Electronics

Authorized Distributor

Click to View Pricing, Inventory, Delivery & Lifecycle Information:

Panasonic:

[EVM-2NSX80B13](#) [EVM-2NSX80B54](#) [EVM-2WSX80B13](#) [EVM-2WSX80B14](#) [EVM-2WSX80B24](#) [EVM-2WSX80B52](#)
[EVM-2WSX80B55](#) [EVM-2WSX80B25](#) [EVM-2WSX80B54](#) [EVM-2WSX80B23](#) [EVM-2NSX80B14](#) [EVM-2NSX80B15](#)
[EVM-2NSX80B16](#) [EVM-2NSX80B22](#) [EVM-2NSX80B23](#) [EVM-2NSX80B24](#) [EVM-2NSX80B25](#) [EVM-2NSX80B52](#)
[EVM-2NSX80B53](#) [EVM-2NSX80B55](#) [EVM-2WSX80B15](#) [EVM-2WSX80B16](#) [EVM-2WSX80B22](#) [EVM-2WSX80B32](#)
[EVM-2WSX80B53](#) [EVM-2NSX80BY2](#) [EVM-2NSX80B34](#)